

Crane/Stop buffers

Crane buffer with base plate

Art.Code	D (mm)	H (mm)	Base plate size L (mm)	S (mm)	d (mm)	Ls (mm)	R (mm)
55490170	40	34	50	2	5,5	40	8
55490270	50	42	63	2	6,5	50	10
55490370	63	53	80	3		63	12,5
55490470	80	66	100	3	9,0	80	16
55490570	100	84	125	4		100	20
55490670	125	104	160	4	11	125	25
55490770	160	131	200	6		160	32
55490870	200	166	250	6	13	200	40
55490970	250	208	315	8		250	50

Crane buffer with screw thread

Art.Code	D (mm)	H (mm)	M (mm)	L (mm)	R (mm)
55190070	40	34	M8	28	8
55190170	50	42	M10	33	10
55190270	63	53		32	12,5
55190370	80	66	M12	37	16
55190470	100	84		36	20
55190570	125	104	M16	46	25
55190670	160	131		44	32
55190770	200	166	M20	49	40
55190870	250	208		47	50

Material: NR (Natural Rubber)
Standard available in $70^{\circ} \pm 5^{\circ}$ Shore A

- H = height
- M = screw thread
- D = diameter
- L = width base plate
- Ls = spacing mounting holes
- d = diameter bore diameter
- S = plate thickness
- R = radius

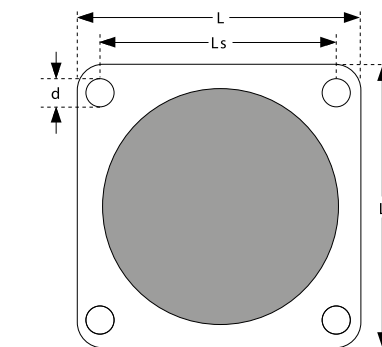

Crane buffer with base plate

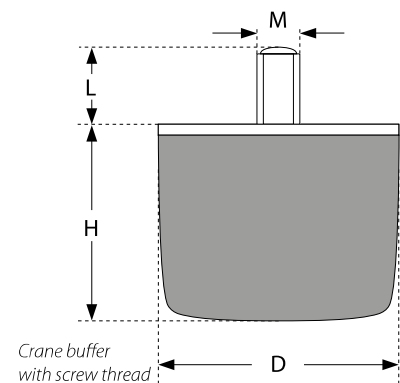

Crane buffer with screw thread

Technical details crane/stop buffers

Diameter 40

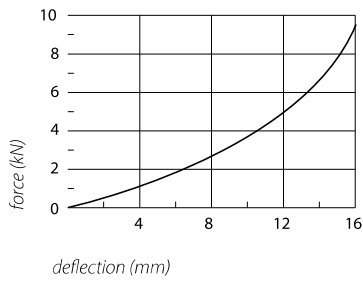

Diameter 50

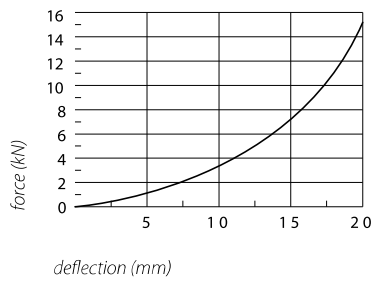

Diameter 63

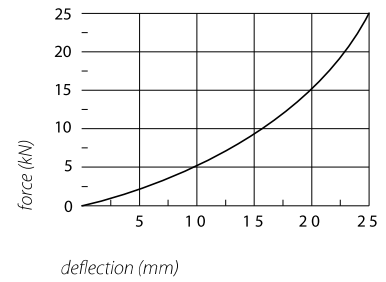

Diameter 80

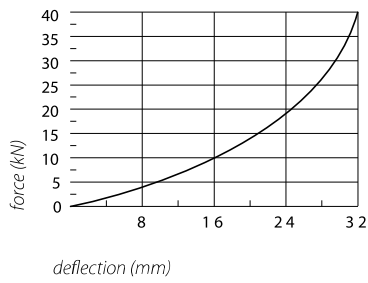

Diameter 100

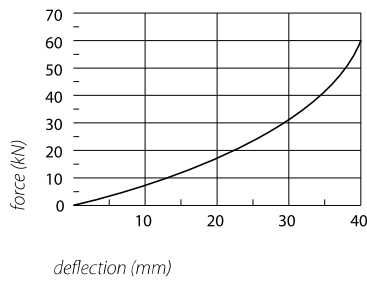

Diameter 125

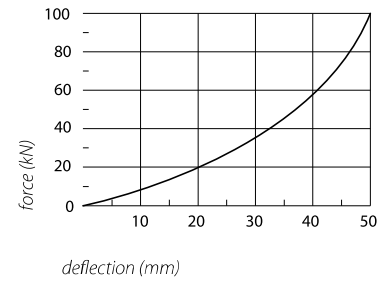

Diameter 160

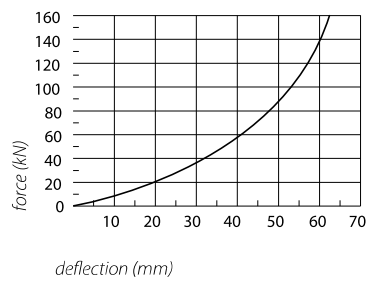

Diameter 200

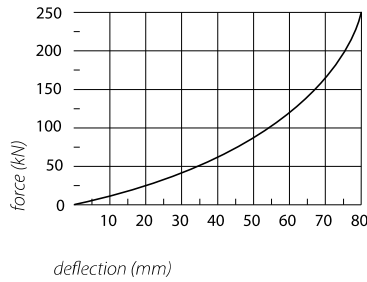

Diameter 250

